



(19) **United States**

(12) **Patent Application Publication**  
**HATTA et al.**

(10) **Pub. No.: US 2012/0280259 A1**

(43) **Pub. Date: Nov. 8, 2012**

(54) **SYSTEM FOR DISPLAYING IMAGES**

(52) **U.S. Cl. .... 257/89; 257/E27.12**

(75) **Inventors: Yoshihisa HATTA, Chu-Nan (TW); Pao-Chung WU, Chu-Nan (TW)**

(57) **ABSTRACT**

(73) **Assignee: CHIMEI INNOLUX CORPORATION, Chu-Nan (TW)**

A system for displaying images is provided. The system includes an emissive display device including a plurality of pixel elements arranged in an array. Each pixel element includes a first substrate and a second substrate disposed thereunder, wherein the first substrate includes at least three subpixel regions. An organic light-emitting device is disposed between the first and second substrates and on the second substrate. At least one patterned polarizer film is disposed between the first and second substrates to be correspondingly located at one of the subpixel regions. At least one retarder film is disposed between the first and second substrates and affixed to the patterned polarizer film.

(21) **Appl. No.: 13/099,292**

(22) **Filed: May 2, 2011**

**Publication Classification**

(51) **Int. Cl. H01L 27/15 (2006.01)**

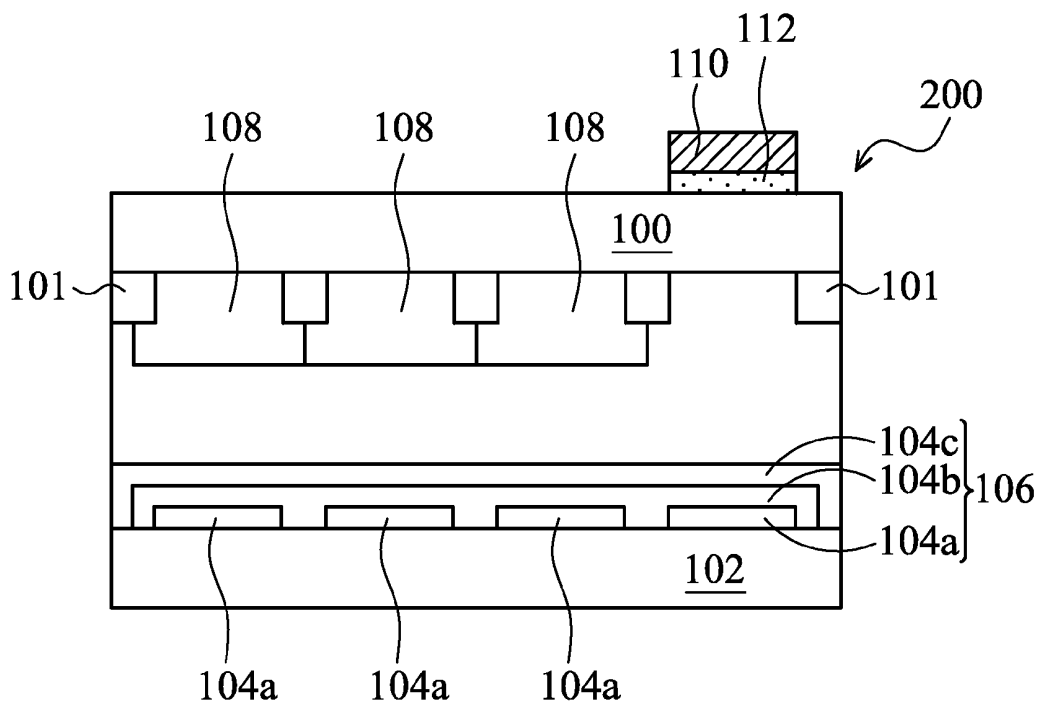

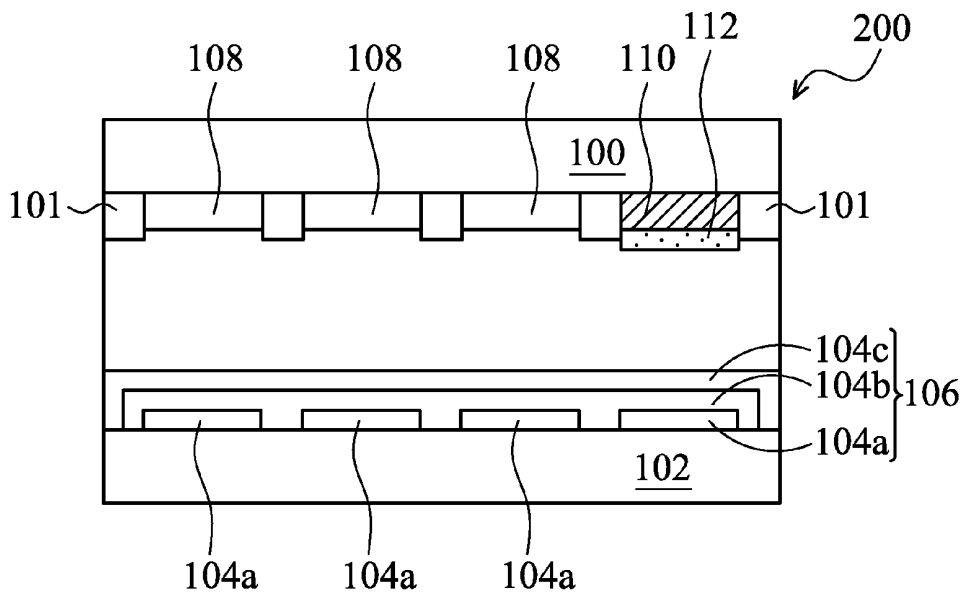

FIG. 1

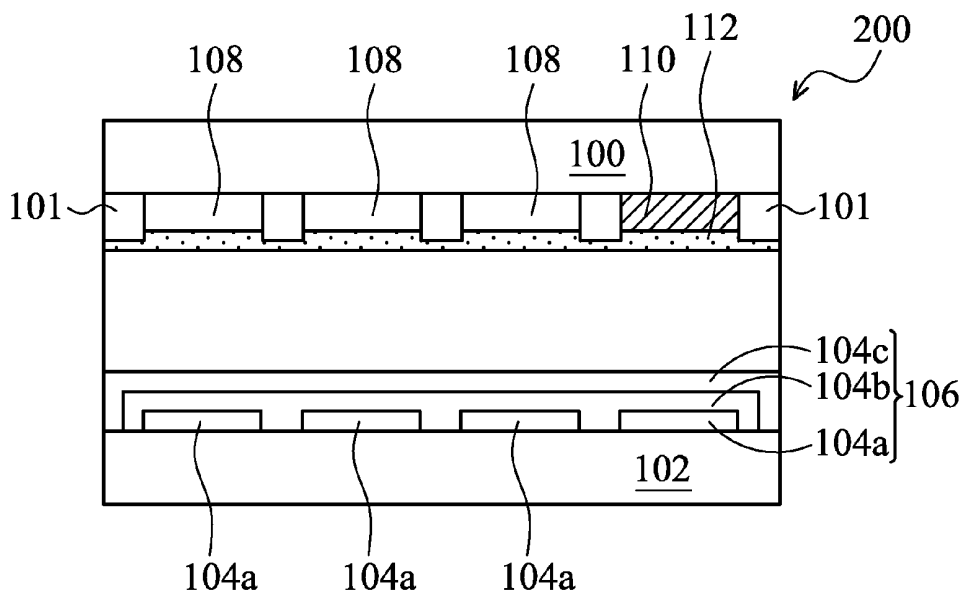

FIG. 2

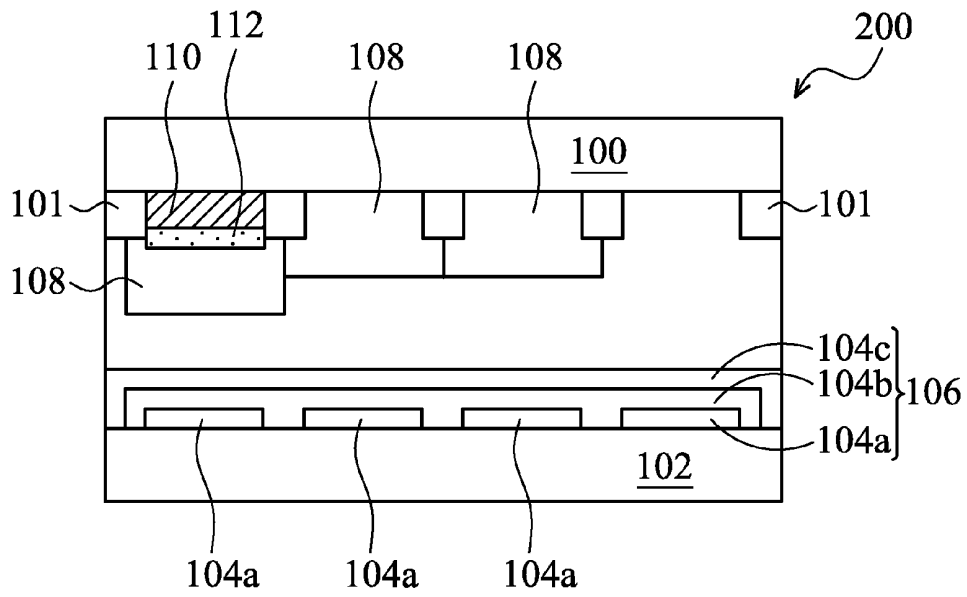

FIG. 3

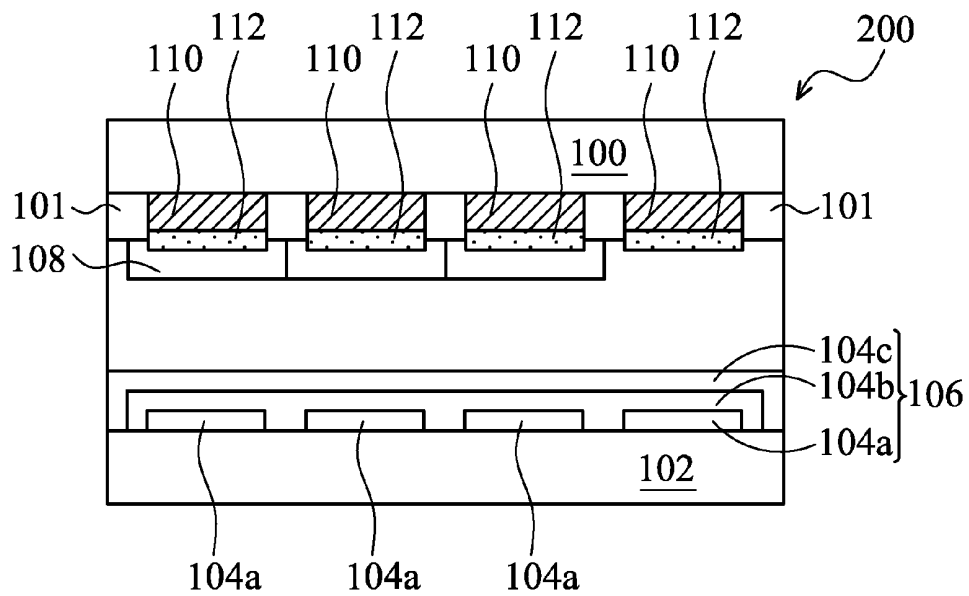

FIG. 4

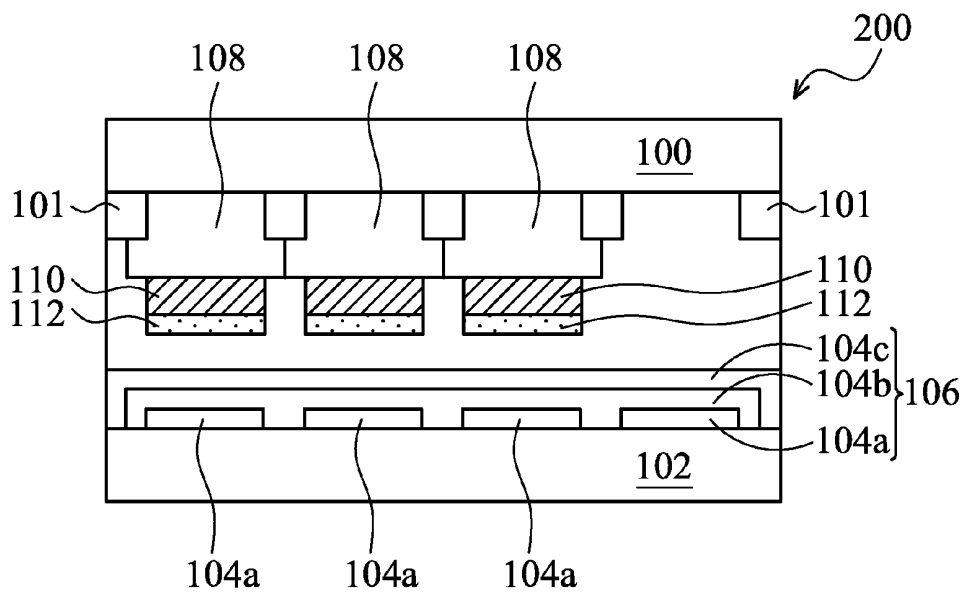

FIG. 5

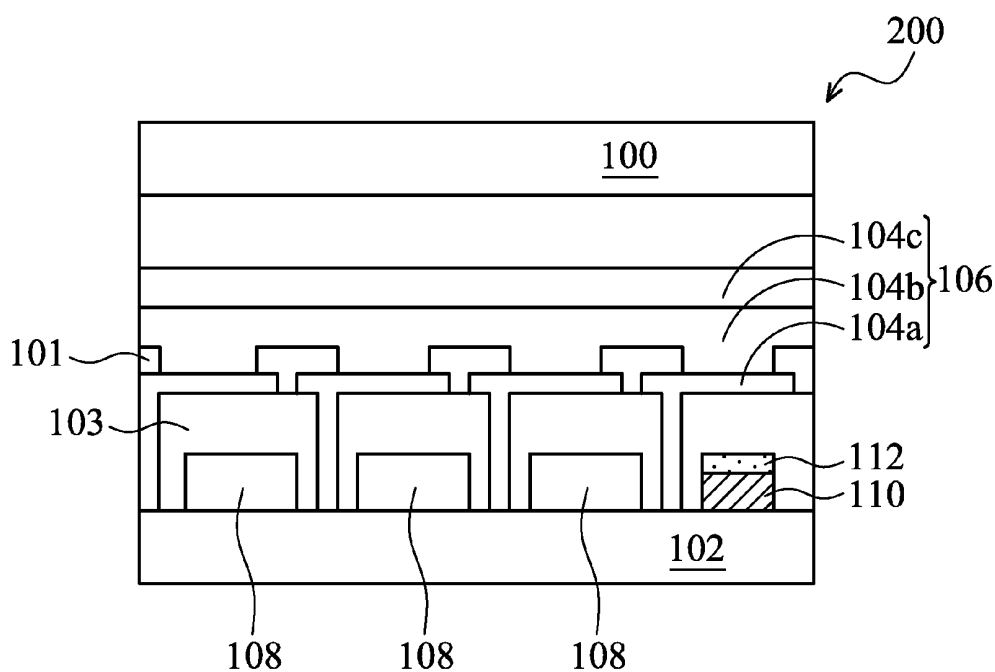

FIG. 6

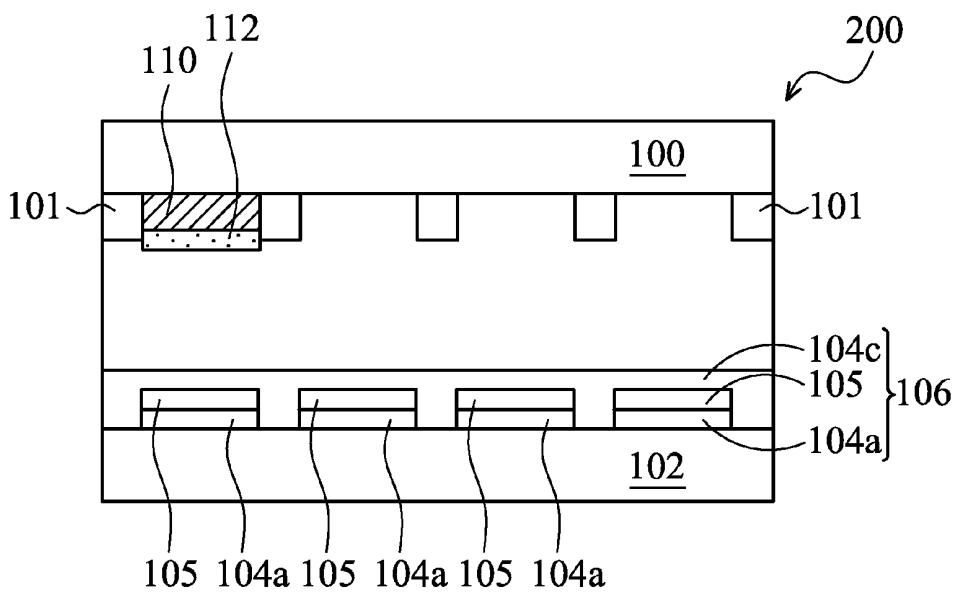

FIG. 7

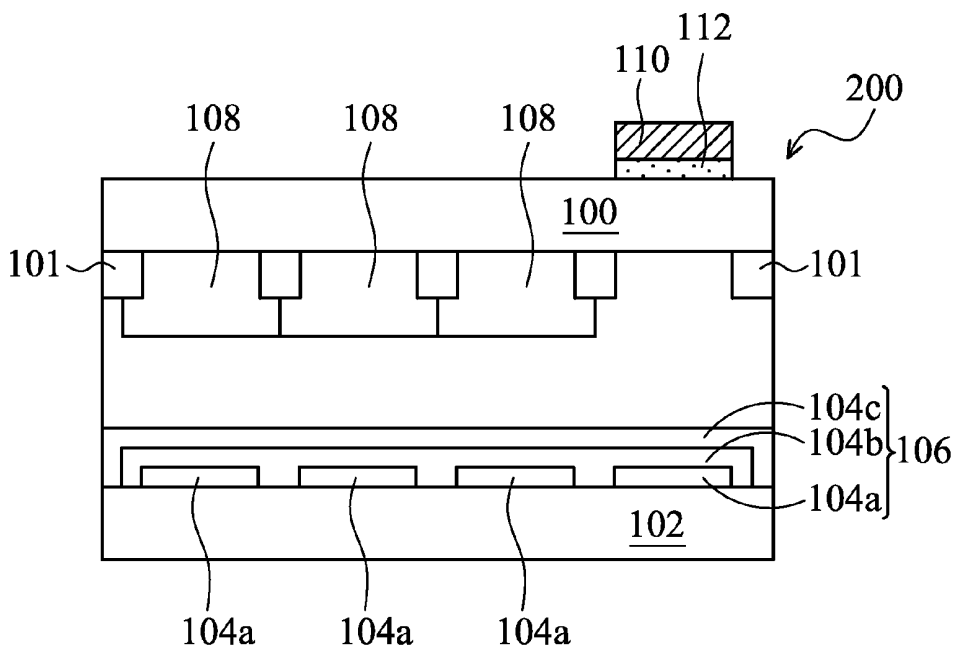

FIG. 8

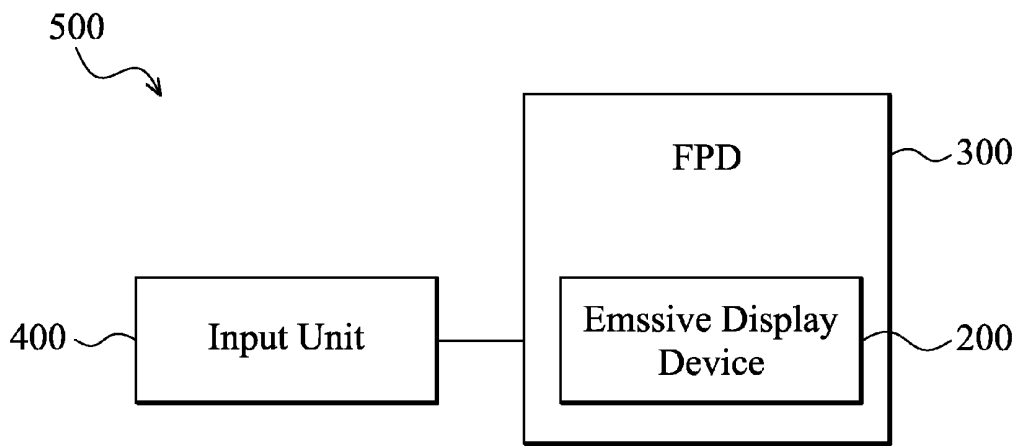

FIG. 9

## SYSTEM FOR DISPLAYING IMAGES

### BACKGROUND OF THE INVENTION

**[0001]** 1. Field of the Invention

**[0002]** The invention relates to a flat panel display (FPD), and in particular to an emissive display device with a polarizer film and a retarder film.

**[0003]** 2. Description of the Related Art

**[0004]** Recently, with the development and wide application of electronic products such as mobile phones, PDAs, and notebook computers, there has been an increasing demand for flat panel displays (FPDs) which consume less electric power and occupy less space. Organic light emitting diode (OLEDs) and organic electroluminescent display (OELDs) are self-emissive and highly luminous, with a wide viewing angle, a fast response time, and a simple fabrication process. Thus, OELD/OLED displays have become an industry display of choice.

**[0005]** An OLED typically has a reflector or reflective electrode to enhance the output of emitted light through one side of the OLED. However, the reflector or reflective electrode also reflects ambient light, which causes the contrast ratio of the OLED to be reduced. As is known in the art, a circular polarizer including a polarizer film and a retarder film is entirely affixed to the exterior surface of a display device including the OLED, so that the ambient light incident on the display device is absorbed by the circular polarizer plate. Accordingly, reflected ambient light can be greatly reduced, thereby reducing glare in the display device to obtain a clear black display.

**[0006]** For emissive display devices, such as organic light-emitting display devices, overall light efficiency is an important factor for performance. In general, the circular polarizer is used to reduce the reflection of the ambient light. However the transparency of the circular polarizer is about 40% to 50%, such that the emitting efficiency of an emissive display device with the circular polarizer is reduced.

**[0007]** Accordingly, there exists a need in the art for development of a novel emissive display device, which is capable of mitigating the deficiencies mentioned above.

### BRIEF SUMMARY OF THE INVENTION

**[0008]** A detailed description is given in the following embodiments with reference to the accompanying drawings. An exemplary embodiment of a system for displaying images comprises an emissive display device comprising a plurality of pixel elements arranged in an array. Each pixel element includes a first substrate and a second substrate disposed thereunder, wherein the first substrate includes at least three subpixel regions. An organic light-emitting device is disposed between the first and second substrates and on the second substrate. At least one patterned polarizer film is disposed between the first and second substrates to be correspondingly located at one of the subpixel regions. At least one retarder film is disposed between the first and second substrates and affixed to the patterned polarizer film.

**[0009]** Another exemplary embodiment of a system for displaying images comprises an emissive display device comprising a plurality of pixel elements arranged in an array. Each pixel element includes a first substrate and a second substrate disposed thereunder, wherein the first substrate includes at least three subpixel regions. An organic light-emitting device is disposed between the first and second

substrates and on the second substrate. At least one patterned polarizer film is disposed on the first substrate and opposite to the organic light-emitting device, to be correspondingly located at one of the subpixel regions. At least one retarder film is disposed between the first substrate and the patterned polarizer film.

### BRIEF DESCRIPTION OF DRAWINGS

**[0010]** The invention can be more fully understood by reading the subsequent detailed description and examples with references made to the accompanying drawings, wherein:

**[0011]** FIGS. 1 to 8 are cross section views of various exemplary embodiments of a system for displaying images, including an emissive display device, according to the invention; and

**[0012]** FIG. 9 schematically shows another embodiment of a system for displaying images.

### DETAILED DESCRIPTION OF INVENTION

**[0013]** The following description is of the best-contemplated mode of carrying out the invention. This description is provided for the purpose of illustrating the general principles of the invention and should not be taken in a limiting sense. The scope of the invention is best determined by reference to the appended claims.

**[0014]** Systems for displaying images are provided. FIG. 1 illustrates an exemplary embodiment of a system for displaying images according to the invention, and in particular, to a system for displaying images, including an emissive display device 200. In the embodiment, the emissive display device 200 comprises a plurality of pixel elements arranged in an array. Here, in order to simplify the diagram, only a pixel element is depicted. The pixel element comprises a first substrate 100, a second substrate 102, an organic light-emitting device (OLED) 106, at least one patterned polarized film 110, and at least one retarder film 112.

**[0015]** The first substrate 100 may serve as a cover plate and/or a color filter substrate, and may include glass, quartz, plastic or other transparent materials. The first substrate 100 of the pixel element includes at least three subpixel regions which are typically surrounded by a black matrix (BM) 101 disposed on the first substrate 100. For example, the pixel element includes four subpixel regions for displaying red, green, blue, and white colors.

**[0016]** The second substrate 102 is disposed opposite to or under the first substrate 100 and may serve as a thin film transistor (TFT) array substrate. The second substrate 102 may also include glass, quartz, plastic or other transparent materials. In some embodiments, the second substrate 102 may include an opaque material such as metal foil substrate.

**[0017]** The OLED 106, such as an active or passive matrix OLED, is disposed between the first and second substrates 100 and 102. In the embodiment, the OLED 106 may also a top-emission type OLED which comprises a plurality of anode layers 104a corresponding to the subpixel regions, an organic light-emitting layer 104b covering the plurality of anode layers 104a, and a cathode layer 104c covering the organic light-emitting layer 104b. The anode layer 104a, such as an ITO or indium zinc oxide (IZO) layer, is disposed on the second substrate 102. The organic light-emitting layer 104b may comprise a stack of a hole injecting layer (HIL), a hole transporting layer (HTL), an electroluminescent layer (EML), an electron transporting layer (ETL), and an electron

injecting layer (EIL). Here, in order to simplify the diagram, only a flat layer is depicted. Moreover, the organic light-emitting layer **104b** may be employed for emitting a white light. Namely, the OLED **106** may be a white OLED. The cathode layer **104c** may comprise a thin metal layer (not shown) and a transparent conductive layer (not shown), such as ITO or IZO layer.

**[0018]** Unlike the conventional circular polarizer for a display device, which is entirely affixed to an exterior surface thereof, in the embodiment, particularly, at least one patterned polarizer film **110** is disposed between the first and second substrates **100** and **102**. Moreover, the patterned polarizer film **110** may correspondingly cover a red, green, blue, or white subpixel region. For example, the patterned polarizer film **110** is located at a white subpixel region of the first substrate **100** and is disposed between the first substrate **100** and the OLED **106**. Moreover, at least one retarder film **112** is disposed between the first and second substrates **100** and **102** and is affixed to the patterned polarizer film **110**. In the embodiment, three color filter films **108** (i.e., red, green, and blue color filter films) may be disposed between the first and second substrates **100** and **102** to respectively cover the subpixel regions without the patterned polarizer film **110** located thereat; however not disposing the color filter films **108** may also be acceptable in some embodiments.

**[0019]** Referring to FIG. 2, which illustrates another exemplary embodiment of a system for displaying images according to the invention. Elements in FIG. 2 that are the same as those in FIG. 1 are labeled with the same reference numbers as in FIG. 1 and are not described again for brevity. In the embodiment, each pixel element of the emissive display device **200** has a structure similar to that of the pixel element shown in FIG. 1. The difference between the pixel element shown in FIG. 2 from the pixel element shown in FIG. 1 is that the retarder film **112** is non-patterned and can be affixed to the color filter films **108**, thereby being located at all of the subpixel regions.

**[0020]** Referring to FIG. 3, which illustrates another exemplary embodiment of a system for displaying images according to the invention. Elements in FIG. 3 that are the same as those in FIG. 1 are labeled with the same reference numbers as in FIG. 1 and are not described again for brevity. In the embodiment, each pixel element of the emissive display device **200** comprises a patterned polarizer film **110** located at a red, green or blue subpixel region. A retarder film **112** is affixed to the patterned polarizer film **110**. Three color filter films **108** (i.e., red, green, and blue color filter films) may be disposed between the first and second substrates **100** and **102** to respectively cover the red, green and blue subpixel regions, such that the patterned polarizer film **110** and the retarder film **112** affixed thereto are covered by one of the color filter films **108**.

**[0021]** In another embodiment, at least two patterned polarizer films **110** having the respective retarder film **112** affixed thereto may cover two of the red, green and blue subpixel regions, such that the patterned polarizer films **110** having the respective retarder film **112** affixed thereto are covered by two of the color filter films **108**, respectively.

**[0022]** Referring to FIG. 4, which illustrates another exemplary embodiment of a system for displaying images according to the invention. Elements in FIG. 4 that are the same as those in FIG. 3 are labeled with the same reference numbers as in FIG. 3 and are not described again for brevity. In the embodiment, each subpixel region of the pixel element of the

emissive display device **200** is covered by a patterned polarizer film **110** having a respective retarder film **112** affixed thereto. Moreover, three color filter films **108** (i.e., red, green, and blue color filter films) may be disposed between the first and second substrates **100** and **102** to respectively cover the patterned polarizer films **110** having a respective retarder film **112** affixed thereto and located at the red, green, and blue subpixel regions; however, not disposing the color filter films **108** may also be acceptable in some embodiments.

**[0023]** Referring to FIG. 5, which illustrates another exemplary embodiment of a system for displaying images according to the invention. Elements in FIG. 5 that are the same as those in FIG. 1 are labeled with the same reference numbers as in FIG. 1 and are not described again for brevity. In the embodiment, each pixel element of the emissive display device **200** comprises three color filter films **108** (i.e., red, green, and blue color filter films) disposed between the first and second substrates **100** and **102** to respectively cover the red, green and blue subpixel regions. Moreover, at least one patterned polarizer film **110** having a respective retarder film **112** affixed thereto is located on one of the color filter films **108**. For example, three patterned polarizer films **110** having a respective retarder film **112** affixed thereto are located on the color filter films **108**, respectively, as shown in FIG. 5.

**[0024]** Referring to FIG. 6, which illustrates another exemplary embodiment of a system for displaying images according to the invention. Elements in FIG. 6 that are the same as those in FIG. 1 are labeled with the same reference numbers as in FIG. 1 and are not described again for brevity. In the embodiment, each pixel element of the emissive display device **200** has a structure similar to that of the pixel element shown in FIG. 1. The difference between the pixel element shown in FIG. 6 from the pixel element shown in FIG. 1 is the OLED **106** is a bottom-emission type OLED and is disposed on an insulating layer **103** (e.g., a planarization layer) on the second substrate **102**, such that at least one patterned polarizer film **110** is embedded in the insulating layer **103** between the second substrate **102** and the OLED **106**. Moreover, a retarder film **112** is correspondingly affixed to the patterned polarizer film **110**. In the embodiment, the patterned polarizer film **110** may correspond to a white subpixel region, and three color filter films **108** (i.e., red, green, and blue color filter films) may be disposed between the first and second substrates **100** and **102** to respectively correspond to the subpixel regions without the patterned polarizer film **110** located thereat; however, not disposing the color filter films **108** may also be acceptable in some embodiments.

**[0025]** In another embodiment, at least one of the color filter films **108** may be covered by a patterned polarizer film **110** having a respective retarder film **112** affixed thereto. For example, each color filter film **108** is covered by a patterned polarizer film **110** having a respective retarder film **112** affixed thereto. In yet another embodiment, at least one patterned polarizer film **110** having a respective retarder film **112** affixed thereto may be covered by one of the color filter films **108**. For example, each color filter film **108** covers a patterned polarizer film **110** having a respective retarder film **112** affixed thereto.

**[0026]** Referring to FIG. 7, which illustrates another exemplary embodiment of a system for displaying images according to the invention. Elements in FIG. 7 that are the same as those in FIG. 1 are labeled with the same reference numbers as in FIG. 1 and are not described again for brevity. In the embodiment, each pixel element of the emissive display

device **200** has a structure similar to that of the pixel element shown in FIG. 1. The difference between the pixel element shown in FIG. 7 from the pixel element shown in FIG. 1 is that the OLED **106** is a side by side OLED, such that the first substrate **100** of each pixel element includes three subpixel regions (i.e., red, green and blue subpixel regions), in which at least one patterned polarizer film **110** having a respective retarder film **112** affixed thereto covers one of the subpixel regions. In the embodiment, the side by side OLED **106** may comprise a plurality of anode layers **104a** corresponding to the subpixel regions, a plurality of organic light-emitting layers **105** (i.e., red, green and blue organic light-emitting layers) respectively covering the plurality of anode layers **104a**, and a cathode layer **104c** covering the plurality of organic light-emitting layers **105**. In some embodiments, a plurality of optional color filters (not shown) may be disposed between the first and second substrates **100** and **102**, such that the pixel element with the side by side OLED **106** has a similar structure as that of the pixel element shown in FIG. 3, 4, 5 or 6.

[0027] According to the foregoing embodiments, since the polarizer film is disposed between the first and second substrate of each pixel element of the emissive display device (which is referred to as an in-cell polarizer film), the total thickness of the emissive display device of the invention may be thinner than that of the conventional emissive display device. Moreover, since the in-cell patterned polarizer film for each pixel element of the emissive display device may be located at a white subpixel region only, the problem of the non-uniform cell gap after the encapsulation process due to the existence of color filter films can be mitigated, while enhancing the emitting efficiency of the emissive display device by reducing the occupied area of the polarizer film in each pixel element of the emissive display device. Additionally, since each subpixel region may have a respective patterned polarizer film, the degree of polarization is adjustable.

[0028] Referring to FIG. 8, which illustrates another exemplary embodiment of a system for displaying images according to the invention. Elements in FIG. 8 that are the same as those in FIG. 1 are labeled with the same reference numbers as in FIG. 1 and are not described again for brevity. In the embodiment, each pixel element of the emissive display device **200** has a structure similar to that of the pixel element shown in FIG. 1. The difference between the pixel element shown in FIG. 8 from the pixel element shown in FIG. 1 is that at least one patterned polarizer film **110** is disposed on the exterior surface of the pixel element to correspondingly cover one of the subpixel regions. For example, the patterned polarizer film **110** is disposed on the first substrate **100** corresponding to a white subpixel region. Also, the patterned polarizer film **110** may be disposed on the first substrate **100** corresponding to a red, green or blue subpixel region, to be located on one of the underlying color filter films **108**. Moreover, at least one retarder film **112** is disposed between the first substrate **100** and the patterned polarizer film **110**. The retarder film **112** may extend to be affixed to the entire surface of the first substrate **100**. In the embodiment, three color filter films **108** (i.e., red, green, and blue color filter films) are disposed between the first and second substrates **100** and **102**; however not disposing the color filter films **108** may also be acceptable in some embodiments.

[0029] In the embodiment, the OLED **106** may be a top or bottom-emission type OLED or a side by side OLED. However, note that the patterned polarizer film **110** and the retarder

film **112** are disposed on the second substrate **102** and opposite to the OLED **106** when the OLED **106** is a bottom-emission type OLED. According to the foregoing embodiments, since the patterned polarizer film for each pixel element of the emissive display device may be disposed at a white subpixel region only, the emitting efficiency of the emissive display device can be enhanced by reducing the occupied area of the polarizer film in each pixel element of the emissive display device. Moreover, since each subpixel region may have a respective patterned polarizer film, the degree of polarization is adjustable.

[0030] FIG. 9 schematically shows another embodiment of a system for displaying images which, in this case, is implemented as a flat panel display (FPD) **300** or an electronic device **500** such as a laptop computer, a mobile phone, a digital camera, a personal digital assistant (PDA), a desktop computer, a television, a car display or a portable DVD player. The FPD **300** may include the described emissive display device **200**, and the FPD **300** may be an organic light-emitting display panel. As shown in FIG. 9, the FPD **300** includes the emissive display device **200** as shown in FIGS. 1 to 8. In some embodiments, the FPD **300** can be incorporated into the electronic device **500**. As shown in FIG. 9, the electronic device **500** includes the FPD **300** and an input unit **400**. Moreover, the input unit **400** is coupled to the FPD **300** and is operative to provide input signals (e.g. image signals) to the FPD **300** to generate images. While the invention has been described by way of example and in terms of preferred embodiment, it is to be understood that the invention is not limited thereto. To the contrary, it is intended to cover various modifications and similar arrangements (as would be apparent to those skilled in the art). Therefore, the scope of the appended claims should be accorded the broadest interpretation so as to encompass all such modifications and similar arrangements.

What is claimed is:

1. A system for displaying images, comprising: an emissive display device comprising a plurality of pixel elements arranged in an array, wherein each pixel element comprises:
  - a first substrate and a second substrate disposed thereunder, wherein the first substrate includes at least three subpixel regions;
  - an organic light-emitting device disposed between the first and second substrates and on the second substrate;
  - at least one patterned polarizer film disposed between the first and second substrates to be correspondingly located at one of the subpixel regions; and
  - at least one retarder film disposed between the first and second substrates and affixed to the patterned polarizer film.
2. The system of claim 1, wherein the first substrate comprises four subpixel regions and each pixel element further comprises three color filter films disposed between the first and second substrates to respectively cover the subpixel regions without the patterned polarizer film located thereat, wherein the patterned polarizer film is located at a white subpixel region.
3. The system of claim 2, wherein the retarder film is affixed to the color filter films.
4. The system of claim 1, wherein each pixel element comprises at least three patterned polarizer films located at the subpixel regions, respectively, and retarder films affixed to the patterned polarizer films, respectively.

5. The system of claim 4, wherein each pixel element further comprises three color films between the first and second substrates to cover the retarder films, respectively.

6. The system of claim 1, wherein each pixel element further comprises three color films between the first and second substrates to cover the subpixel regions, respectively, such that the patterned polarizer film and the retarder film are covered by one of the color films.

7. The system of claim 1, wherein each pixel element further comprises three color films between the first and second substrates to cover the subpixel regions, respectively, such that the patterned polarizer film and the retarder film are located on one of the color films.

8. The system of claim 1, wherein the organic light-emitting device is a top or bottom-emission type organic light-emitting device.

9. The system of claim 1, wherein the organic light-emitting device is an active or passive matrix organic light-emitting device.

10. The system of claim 1, wherein the organic light-emitting device is a white organic light-emitting device.

11. The system of claim 1, wherein the organic light-emitting device is a side by side organic light-emitting device.

12. The system as claimed in claim 1, further comprising:  
a flat panel display comprising the emissive display device;  
and

an input unit coupled to the flat panel display and operative to provide input signals to the flat panel display, such that the flat panel display displays images.

13. The system of claim 12, wherein the system is an electronic device comprising the flat panel display.

14. The system of claim 13, wherein the electronic device is a laptop computer, a mobile phone, a digital camera, a personal digital assistant, a desktop computer, a television, a car display or a portable DVD player.

15. A system for displaying images, comprising:

an emissive display device comprising a plurality of pixel elements arranged in an array, wherein each pixel element comprises:

a first substrate and a second substrate disposed thereunder, wherein the first substrate includes at least three subpixel regions;

an organic light-emitting device disposed between the first and second substrates and on the second substrate;

at least one patterned polarizer film disposed on the first substrate and opposite to the organic light-emitting device, to be correspondingly located at one of the subpixel regions; and

a retarder film disposed between the first substrate and the patterned polarizer film.

16. The system of claim 15, wherein the first substrate comprises four subpixel regions and each pixel element further comprises three color filter films disposed between the first and second substrates to respectively cover the subpixel regions without the patterned polarizer film located thereat, wherein the patterned polarizer film is located at a white sub-pixel region.

\* \* \* \* \*

专利名称(译)	用于显示图像的系统		
公开(公告)号	<a href="#">US20120280259A1</a>	公开(公告)日	2012-11-08
申请号	US13/099292	申请日	2011-05-02
[标]申请(专利权)人(译)	群创光电股份有限公司		
申请(专利权)人(译)	奇美群创光电		
当前申请(专利权)人(译)	群创光电		
[标]发明人	HATTA YOSHIHISA WU PAO CHUNG		
发明人	HATTA, YOSHIHISA WU, PAO-CHUNG		
IPC分类号	H01L27/15		
CPC分类号	H01L27/3213 H01L51/5281 H01L27/322		
其他公开文献	US8796704		
外部链接	<a href="#">Espacenet</a> <a href="#">USPTO</a>		

摘要(译)

提供了一种用于显示图像的系统。该系统包括发光显示设备，该发光显示设备包括以阵列布置的多个像素元件。每个像素元件包括第一基板和设置在其下的第二基板，其中第一基板包括至少三个子像素区域。有机发光装置设置在第一和第二基板之间以及第二基板上。至少一个图案化偏振膜设置在第一和第二基板之间，以对应地处于子像素区域之一处。至少一个延迟膜设置在第一和第二基板之间并固定到图案化的偏振膜上。

